

# CARR5115

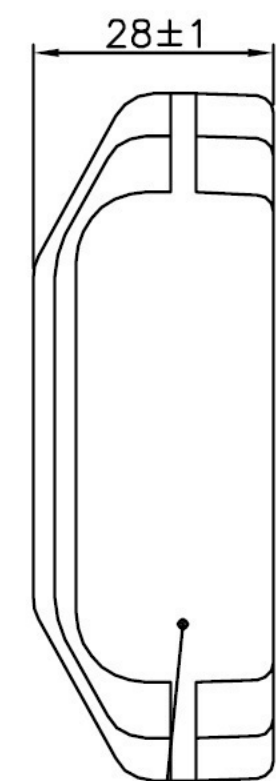

Case:Black

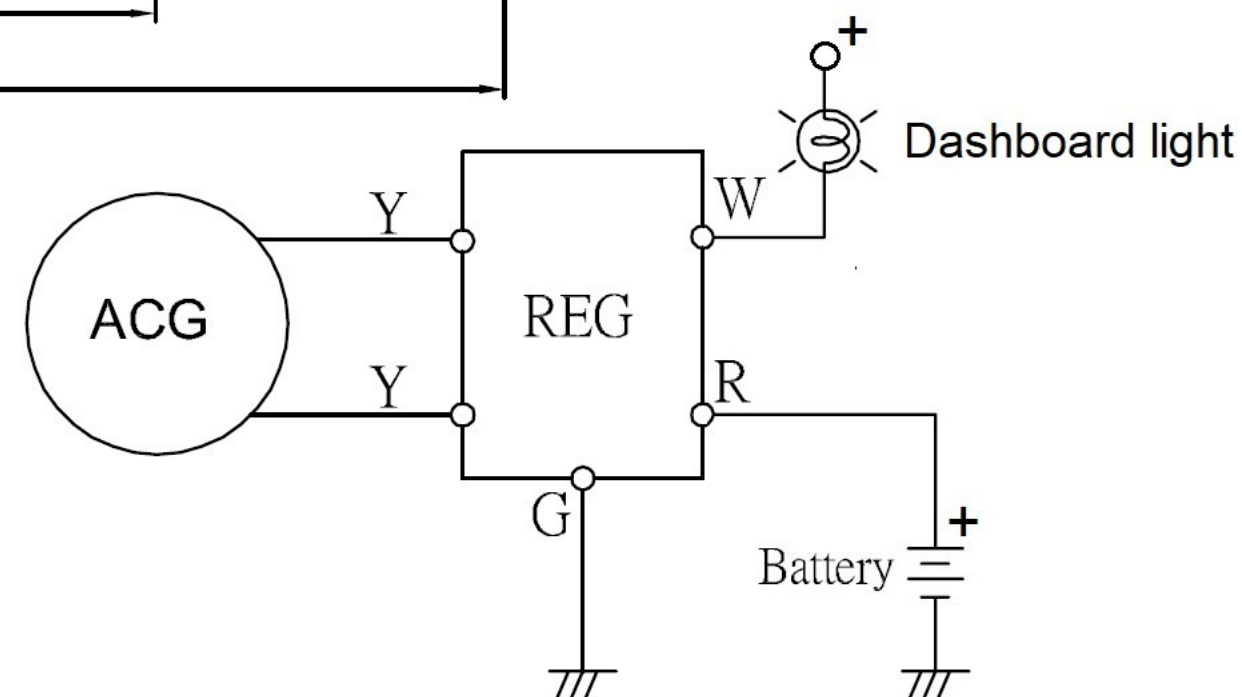
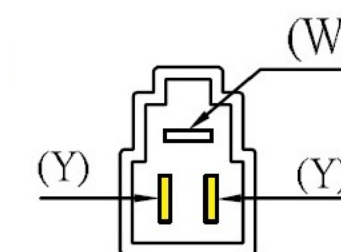
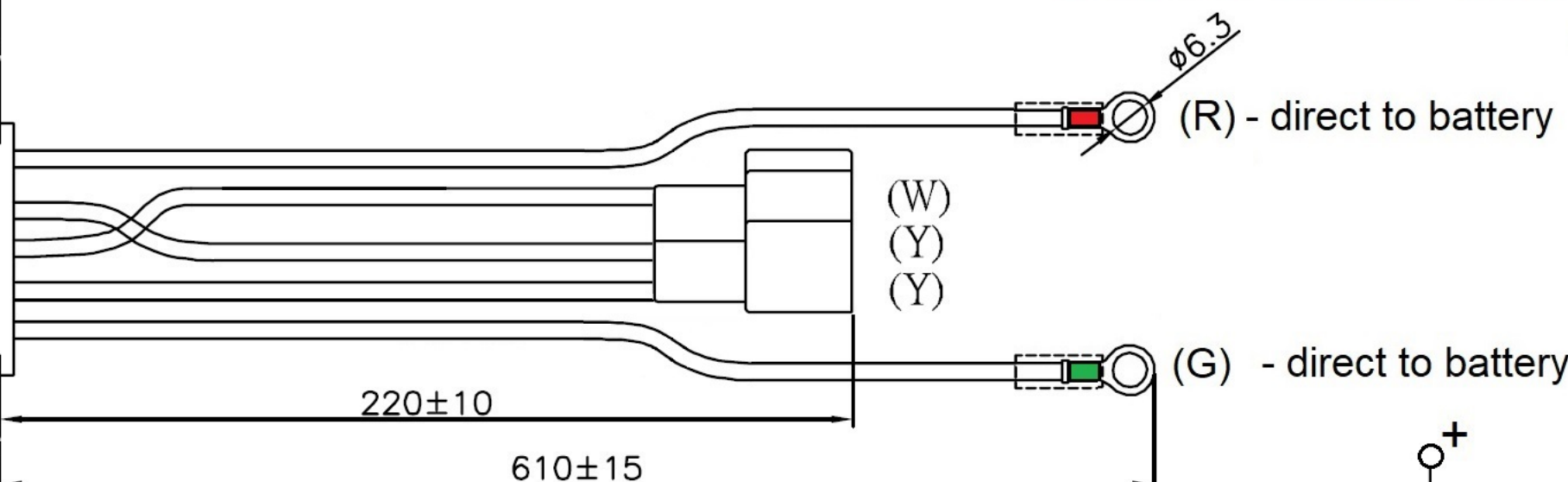
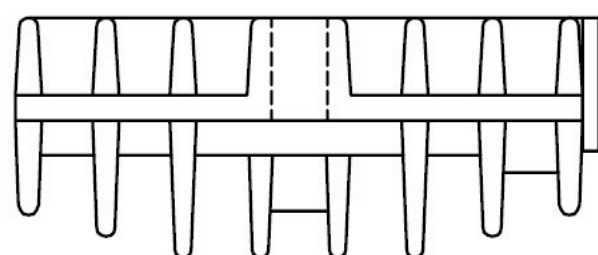
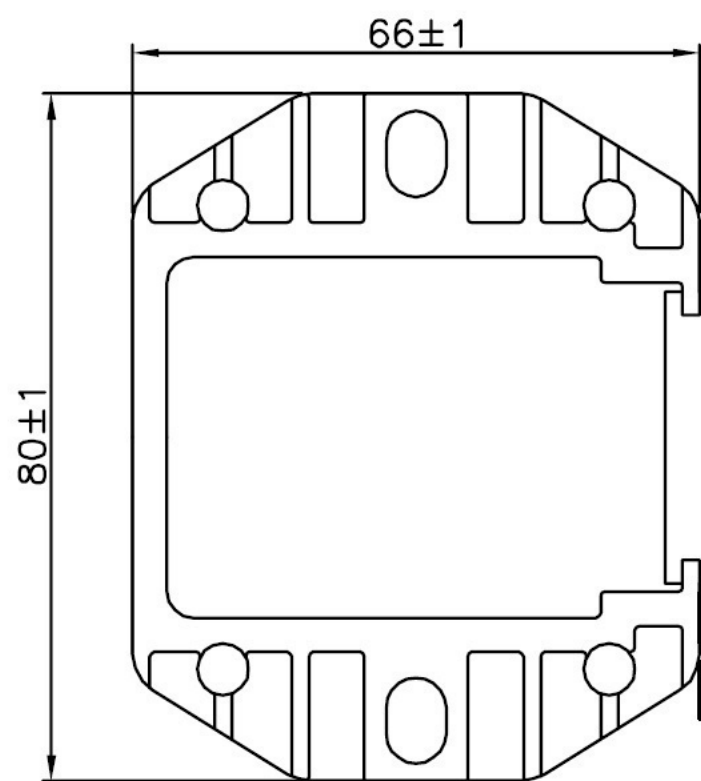

reliability test items	Testing description
Thermal shock test	+100°C 1 hr,-30°C 1 hr 200 cycles
On-off test	20A on (30Mins) ~off(30mins), test1000hrs,test with ACG 5000rpm, case tem less than 110°C
Temp cycling Cold-hot water test	+80°C hot water for 30mins,after 5mins interval, put it in 0°C cold water for 30mins, test 20 cycles
Drop test	Drop from 1meter height to floor, drop two items in each of X, Y and Z direction, total 6 times.
Vibration test	30g,50-50Hz 1min sweep fro 3 hrs in each of X,Y and Z direction, total test 9hrs

No	Name	Specification
1	Operation Temp.	-20°C~+60°C
2	Storage Temp.	-30°C~+80°C
3	Regulated Voltage	14.5±0.5V
4	Max regulated current	20A (case temp. <110°C)
5	When the battery is 11.5±0.3V and 15.5±0.3V, the indicator light is on, the rest are off.	